

# 1 受付業務

## ① 開閉栓等申込

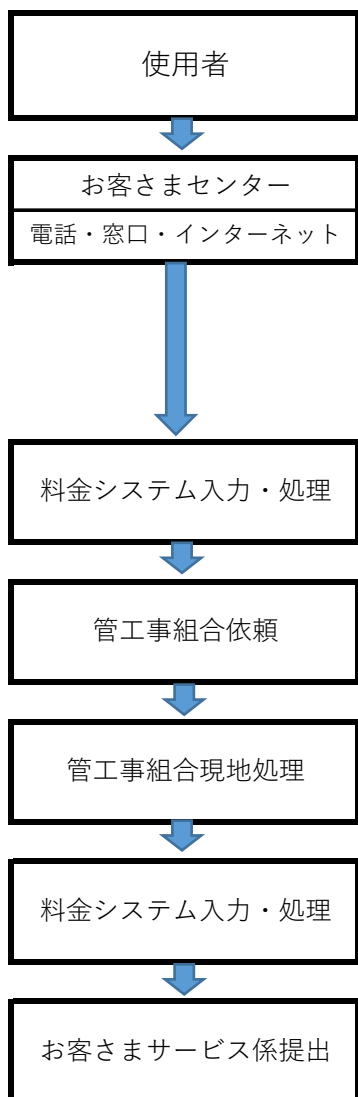

## ③ 各種申込

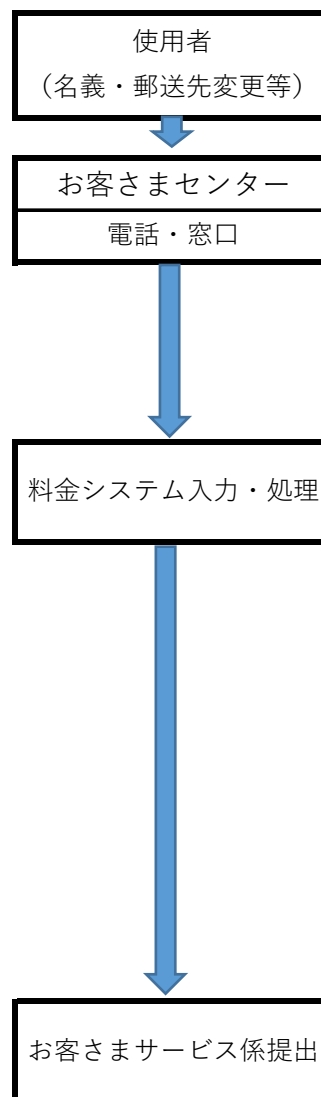

## ② 履行延期特約申込・納入済証明書

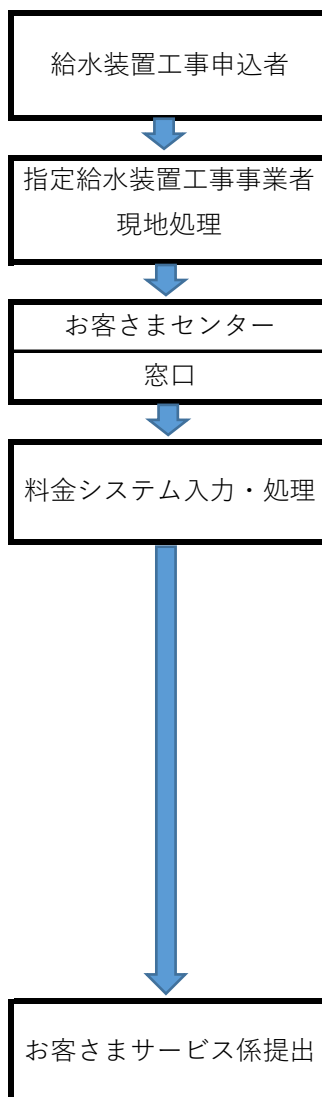
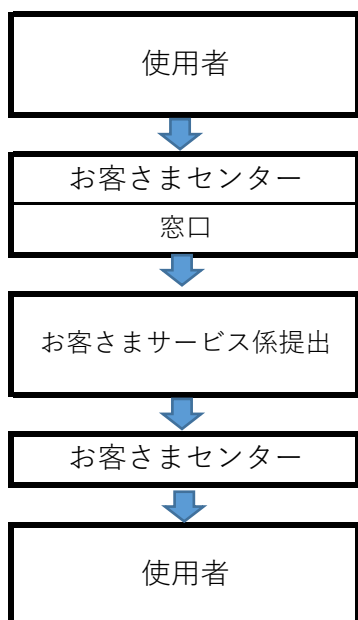

## 2 調定業務（検針業務含む）

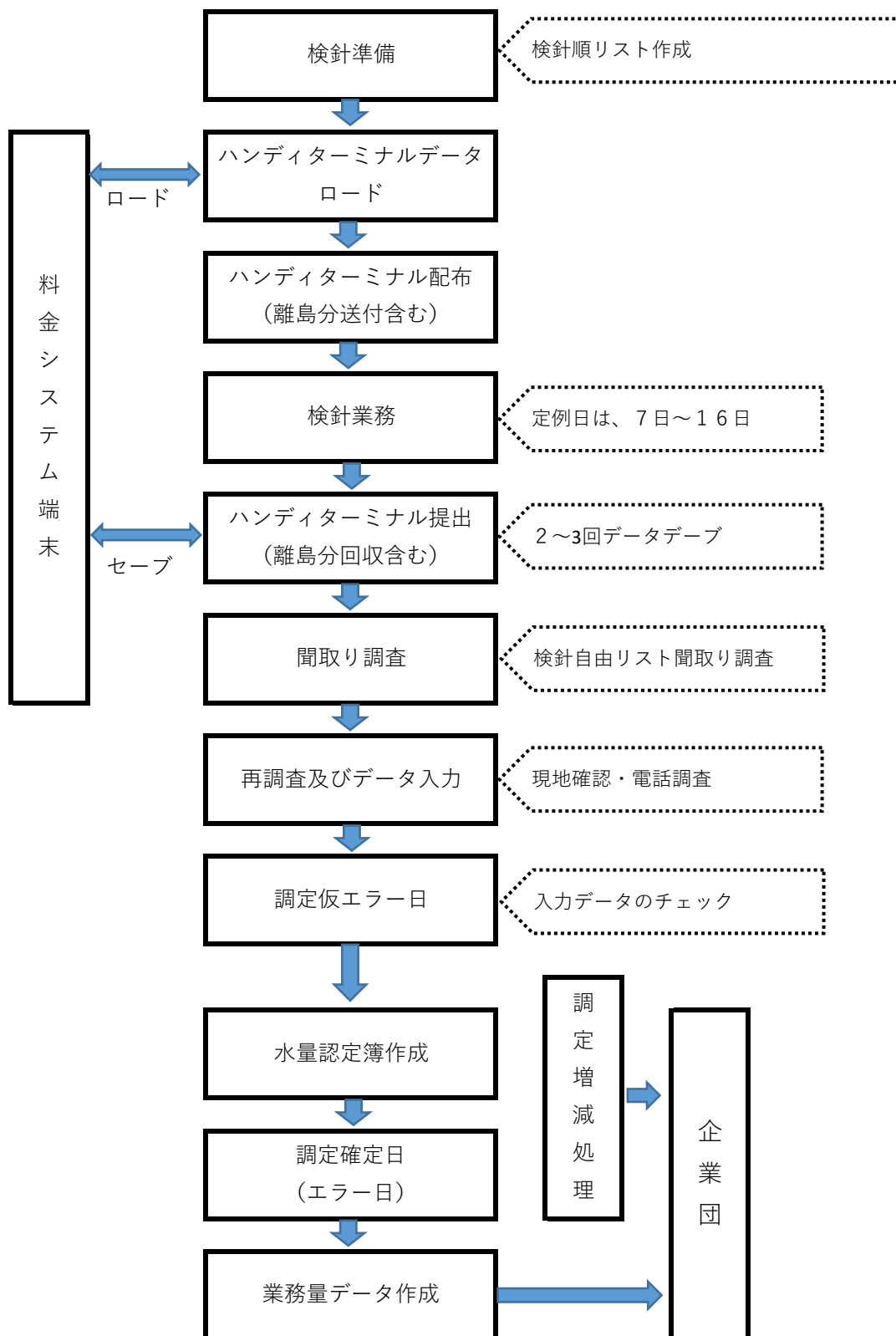

### 3 収納業務

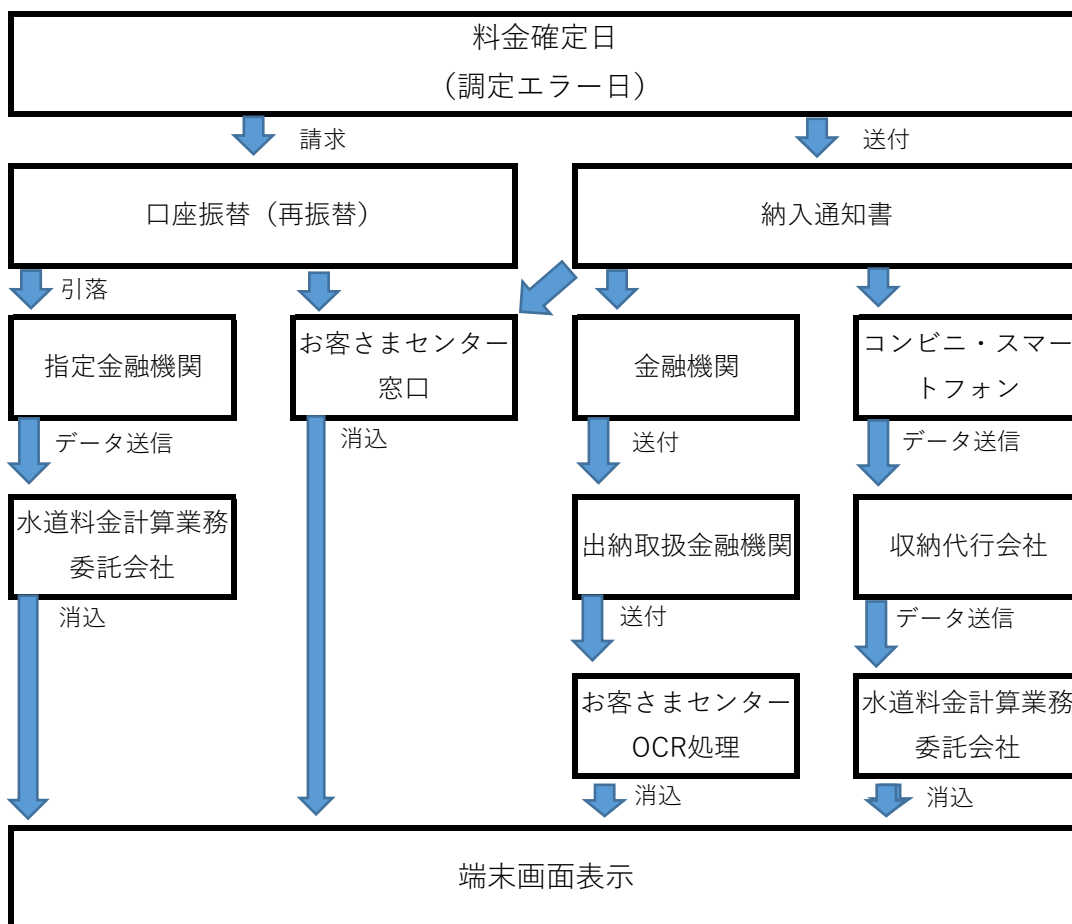

#### 4 滞納整理業務

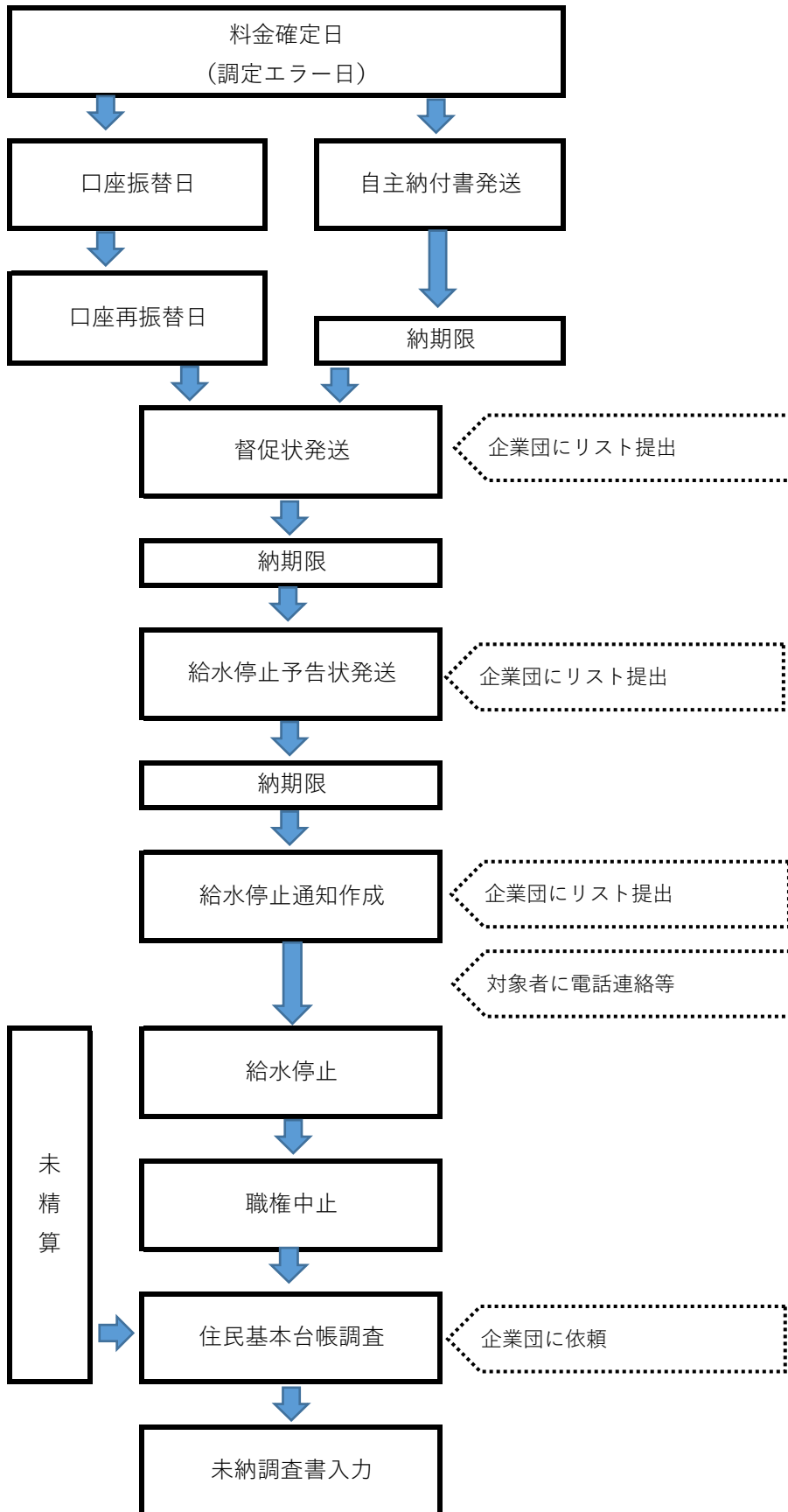

## 5 債権管理業務

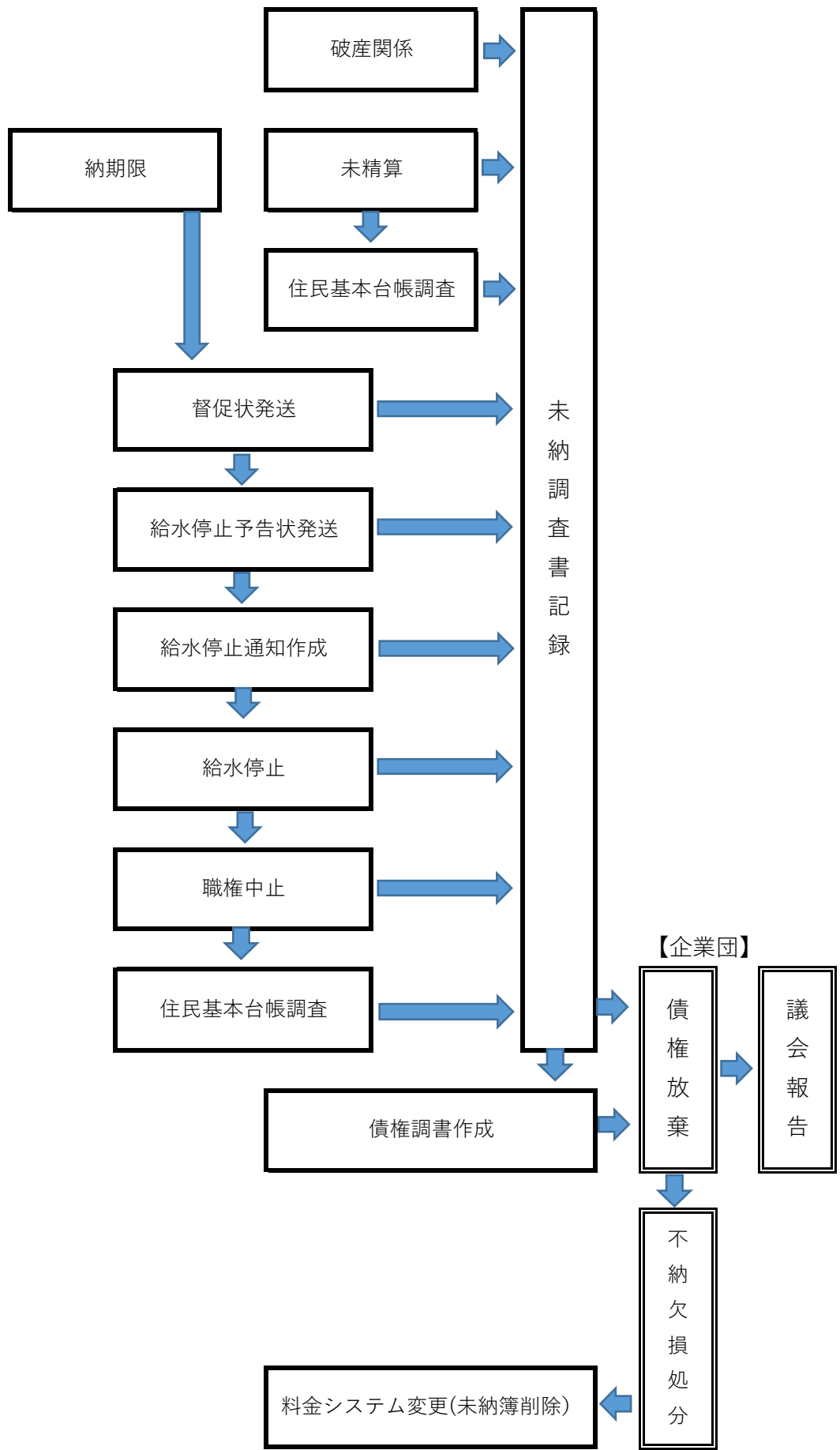

## 6 不回転等メーター交換業務

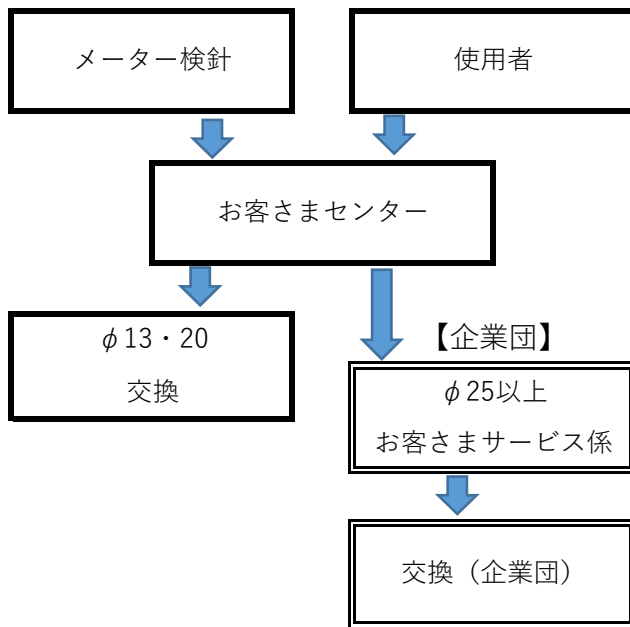

## 7 過誤納入還付業務

